

PARTS LIST				
ITEM	QTY	PART NUMBER	DESCRIPTION	MATERIAL
1	4	LEGS	2" SQ. TUBE X 34"	STEEL
2	2	TOP FRAME 36	2" SQ. TUBE X 36"	STEEL
3	2	TOP FRAME 32"	2" SQ. TUBE X 32"	STEEL
4	2	LEDGER	1/4" X 1" X 32"	STEEL
5	4	SLAG PAN	10 GA. SHEET	STEEL
6	4	32" SHELF SUPPORTS	1" SQ. TUBE X 32"	STEEL
7	34	SPACERS	1/4" X 1.5" X 3/4"	STEEL
8	16	REMOVABLE SLATS	1/4" X 1" X 31-7/8"	STEEL
9	1	SHELF	3/4" X #9 EXPANDED METAL	STEEL

BILL OF MATERIALS PROVIDE BY THE COMMITTEE

- 1EA. 2" SQ. TUBE X 24'
- 1EA 1" SQ. TUBE X 12'
- 2EA 1/4" X 1" FLAT BAR X 20'
- 1EA 1/4" X 1" FLAT BAR X 3'
- 1 EA 1/4" X 1.5" FLAT BAR X 3'
- 1EA 10 GA. X 4'X4' SHEET
- 1 EA 3/4" X #9 X 4'X4' EXPANDED

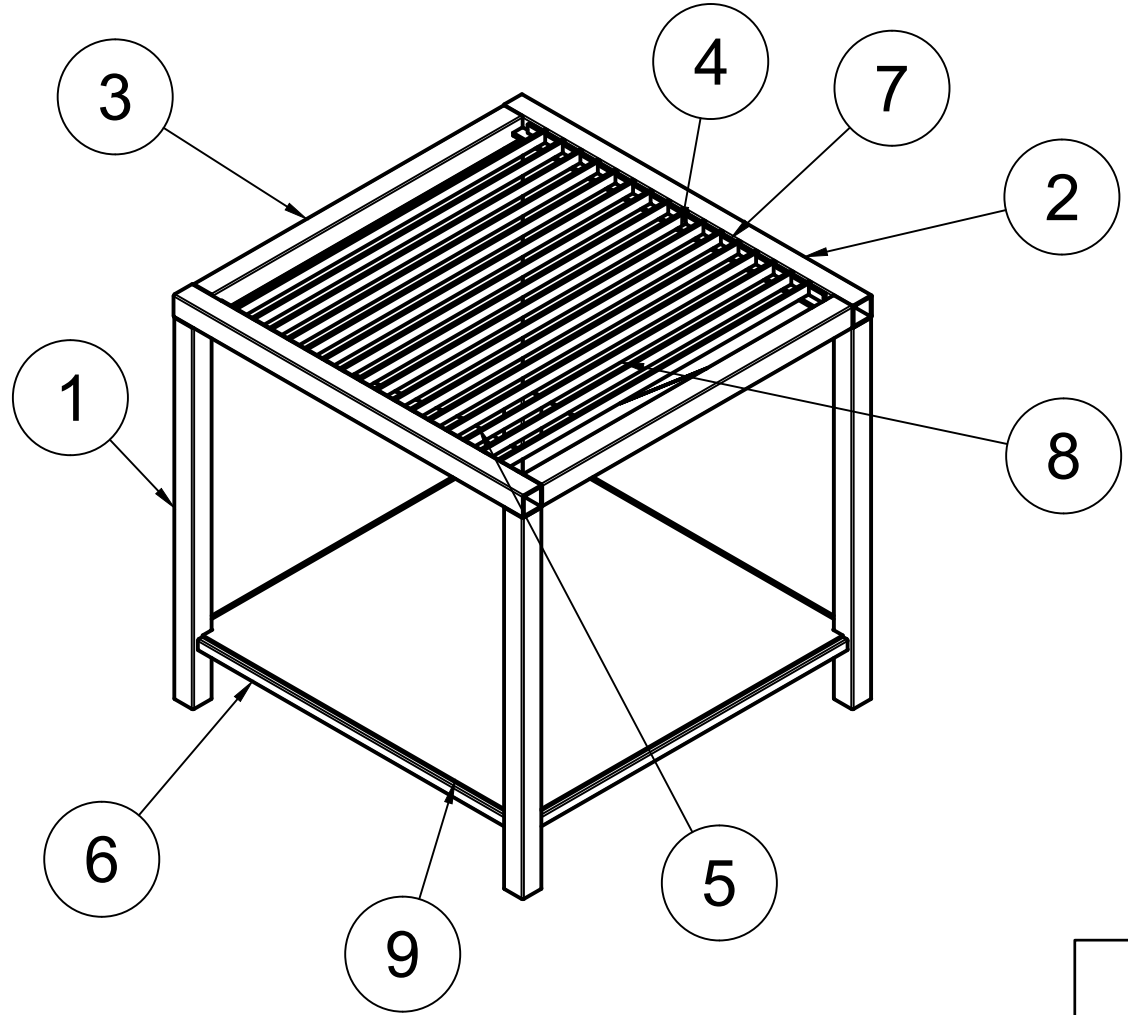

**SkillsUSA Region 7**

**2023 Fabrication Contest-Plasma Table**

Drawn By: M. Rust	Date: 1/23/2023
Sheet Size B	Scale 1:20
Sheet: 1/2	

- NOTES**
1. (GMAW OR FCAW) - 2 JOINTS 1G, 2 JOINTS 3G
  2. (E-6010) 2 WELDS 2F 2 WELDS 3F \*\*\*MUST GET INSPECTION BEFORE WELDING IN SLAG PAN\*\*\*
  3. (E-7018) 2 WELDS 2F 2 WELDS 3F \*\*\*MUST GET INSPECTION BEFORE WELDING IN SLAG PAN\*\*\*
  4. (GMAW OR FCAW) - ANY POSITION
  5. (GMAW OR FCAW) CENTER WELD ON SPACER ANY POSITION
  6. (GMAW OR FCAW) ANY POSITION
  7. (PAC OR OFC) \*\*\*CUTS MUST BE INSPECTED PRIOR TO WELDING\*\*\*

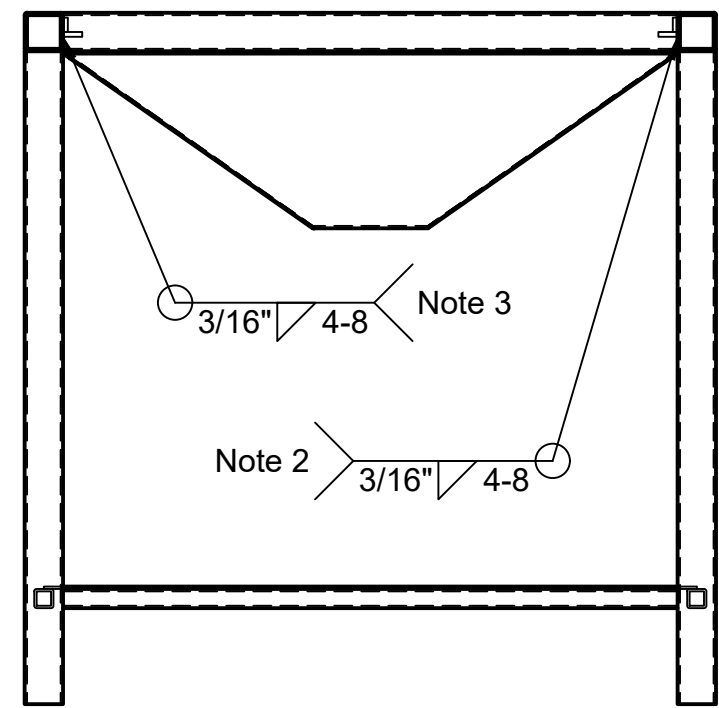
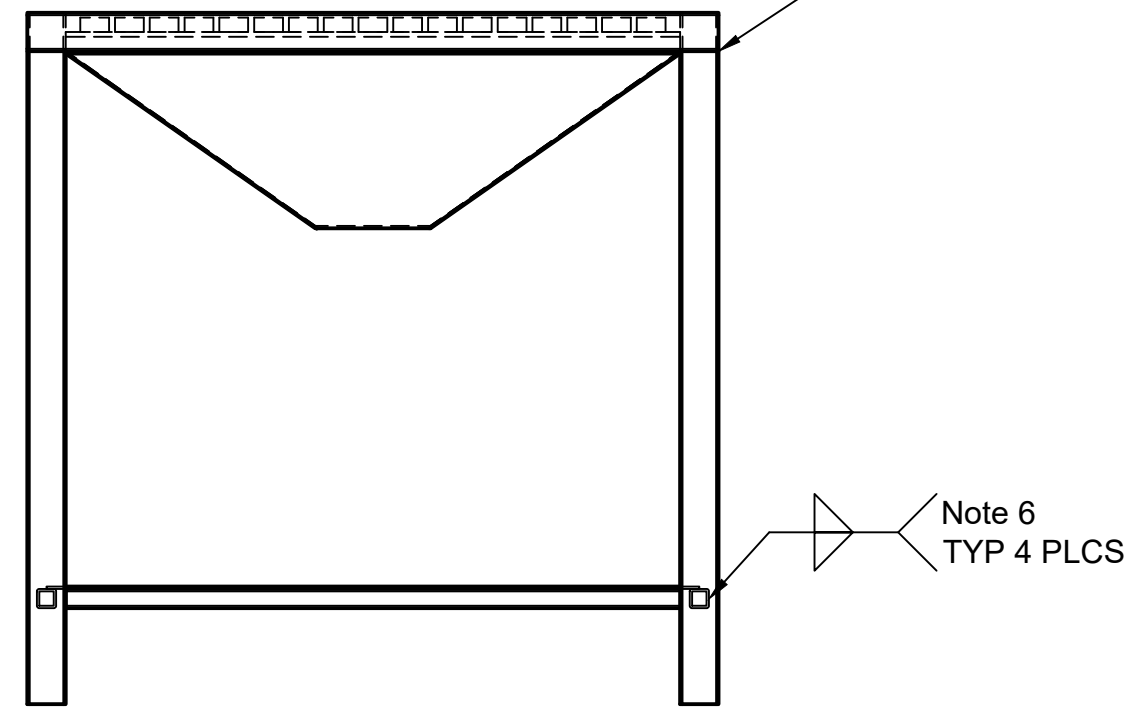
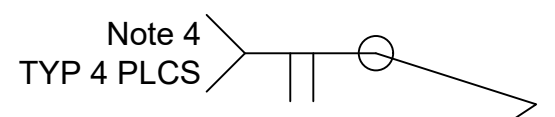
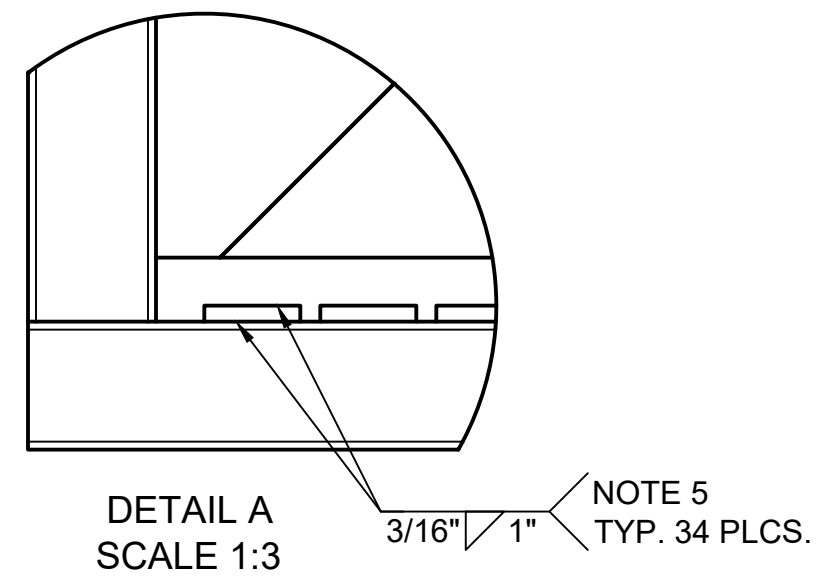
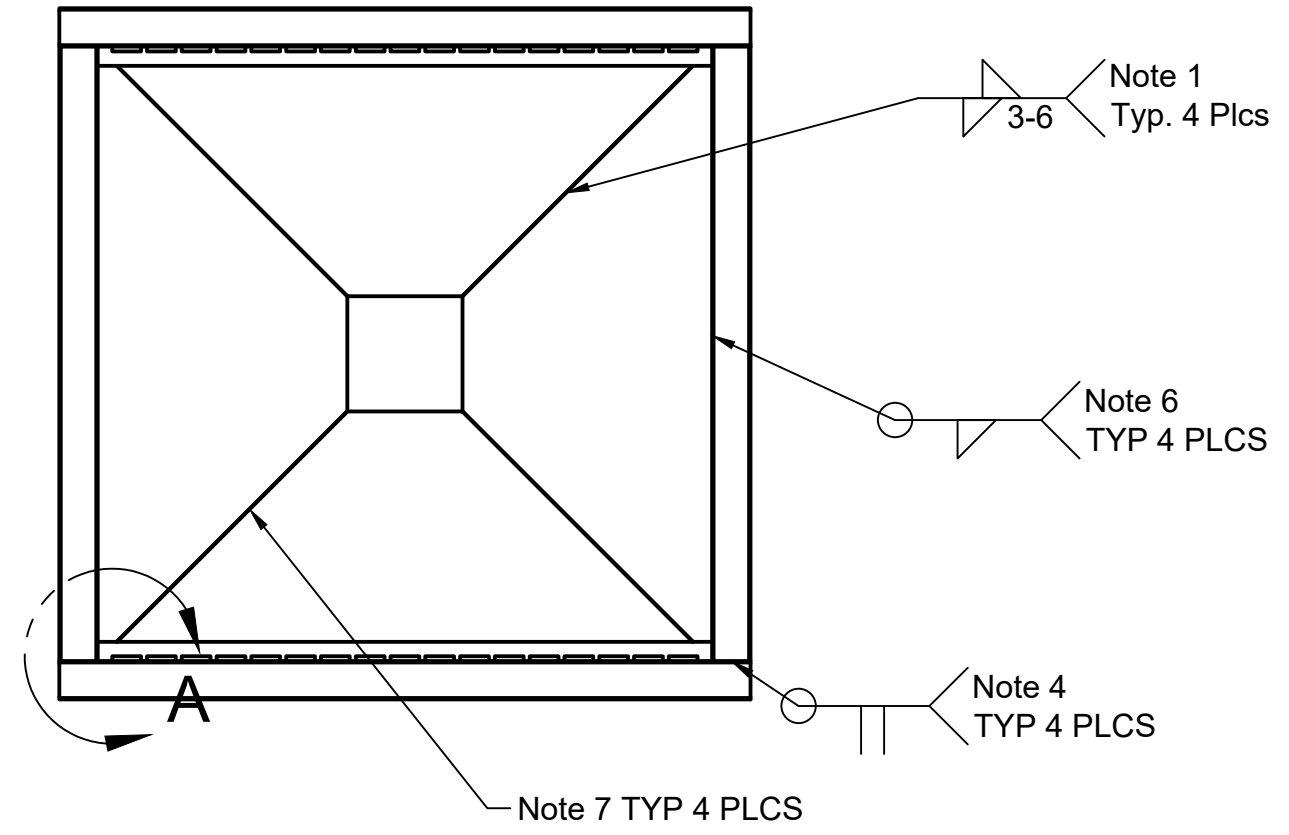

<b>SkillsUSA Region 7 2023</b>		
<b>Fabrication Contest - Plasma Table</b>		
Drawn By: M. Rust		Date: Date 1/23/2023
Sheet Size B	Scale 1:20	Sheet: 2/2