

PARTS LIST		
ITEM	QTY	DESCRIPTION
1	1	1/4X9X8
2	1	1/4X7X8
3	1	1/4X6.5X6
4	1	1/4X3.5X6.5 - 30DEG.
5	1	1/4X4.5X6
6	1	1/4X5X6.5 30 - DEG
7	1	1/4X4X4

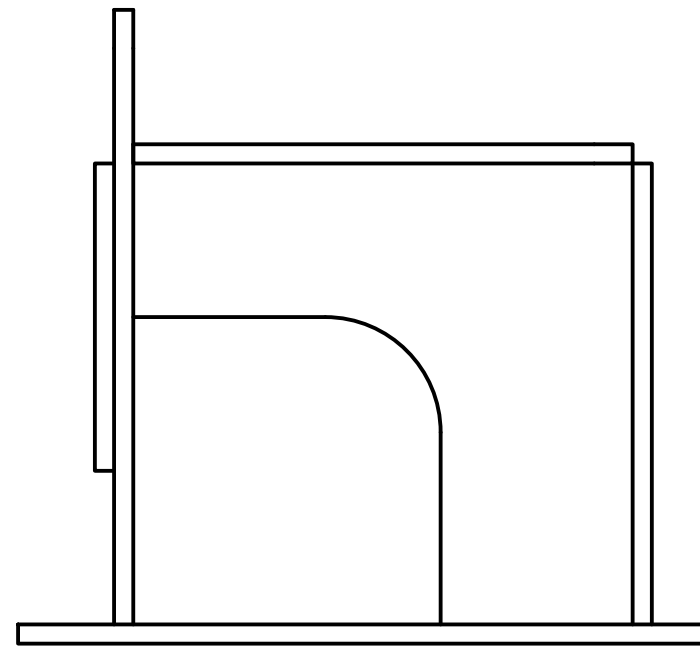
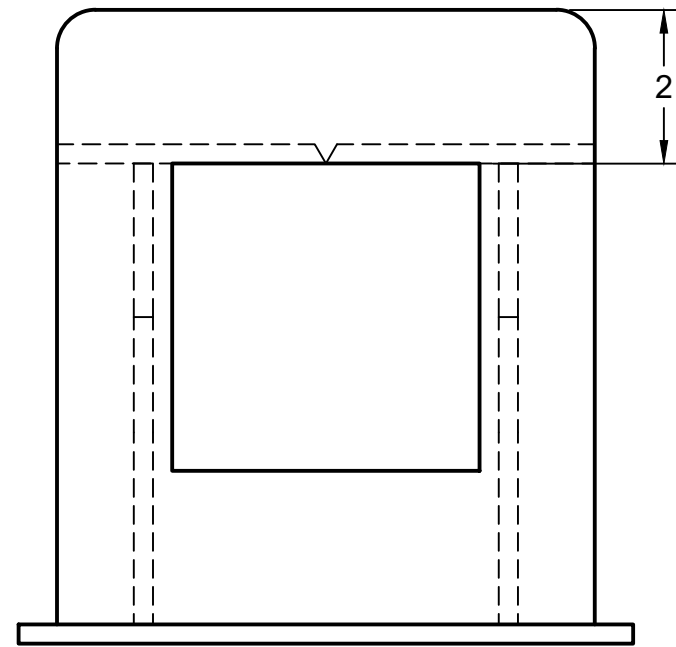

GENERAL NOTES

1. TACK COMPLETE
ASSEMBLY IN ANY POSITION
2. WELDING TO BE
COMPLETED WITH PLATE D
FLAT ON THE TABLE
3. ALL VERTICAL WELDS TO BE
WEDED IN THE UPHILL
PROGRESSION

SKILLSUSA

SMAW,GMAW,FCAW

REGION 7

1/1